

www.tora.us.fm/tnk1/

My thanks to my daughter

For her help.

Rami Nir; "Israel" 2021. ©

A Point in Time
Joseph is 37 years old
The beginning of the hard starvation
Bahar Yusef = Joseph's Water

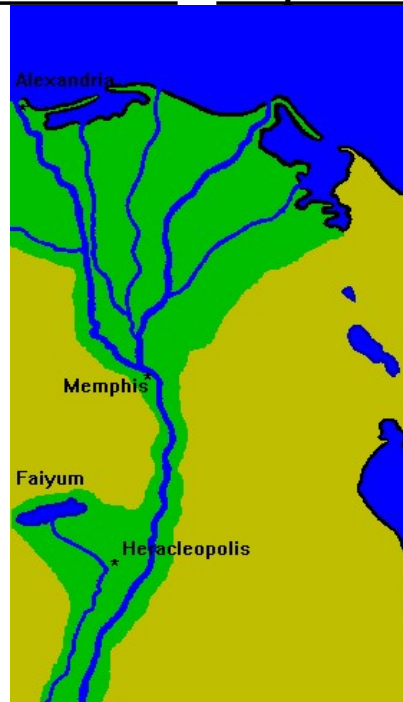

A historical monument: the "**Bahar Yusef**" Canal.

This canal follows the Nile from the 15th Nome and runs parallel to the great river's western bank, ending at lake Karun (the ancient lake Moeris), for the purpose of developing an artificial oasis at "**Fayoum**". In fact, this artificial oasis at Fayoum is none other than "Goshen", which in Hebrew means: plenty of water on a rich land that does not suffer when there is no rain. **Pharaoh Senusret II** (see www.touregypt.net/Kings.htm) was the one that gave the order to execute the digging of this canal as well the oasis at **Fayoum**. One must understand that digging such a long canal happens for a reason, a project that is meant to deal with a catastrophe, like the years of starvation that happened at that time. It is true that such a catastrophe and its consequences can be easily and quickly forgotten once they pass; yet it would be difficult to deny the logic of the situation.

While this not written in the Bible, I have no doubt that **Joseph** prepared the Bahar Yusef Canal as well as the Oasis at **Fayoum**, as he had the vision to save Egypt and then bring

his father's family into Egypt during the 7 bad years of starvation, in order to save them = (Genesis 45, 7-8) = **“And God sent me before you to give you a remnant on the earth and to save you alive for a great deliverance So now it was not you that sent me hither but God and He hath made me a father to Pharaoh and lord of all his house and ruler over all the land of Egypt”**... So it was **Joseph's** idea to dig this canal with the aim of creating the land of Goshen, as it was the interest of **Pharaoh Khakheperre**, and also because **Jacob's** family were shepherds = (Genesis 46, 34) = **for every shepherd is an abomination unto the Egyptians...** (Quotations are taken from the American English version of the Bible presented in www.mechon-mamre.org/i/t/t0138.htm and www.vatican.va/).

At the age of 30 years = (“Genesis” 41- 46) = **Joseph** solved the dream of **Pharaoh Amenemhet II of Dynasty XII**. The digging of the Canal began during the 7 good years that followed Pharaoh's dream, and was probably operational by the **6th year of Pharaoh Senusret II' reign**. One can imagine that great historical moment when **Joseph's water** arrived through the canal into **Fayoum**, a moment which deserved to be **A Point in Time** for **Egyptian History**, for **Joseph** and for **Pharaoh Khakheperre = Senusret II**, as it was the beginning of the 7 years of hard starvation. In that year **Joseph** became the **ruler over all the land of Egypt**, at the age of **37**, and **Fayoum** became an enduring **Egyptian** economical center.

Thus we can mark **A Point in Time**:

Joseph is 37 years old = the beginning of the 7 years of hard starvation = **in the year 6 of Pharaoh Khakheperre** known as **Senusret II** of Dynasty XII = **Egypt is saved**.

However, no archeological finding can be directly linked to the Israelite's time in Egypt, since the **XVIII Dynasty of Pharaohs: Who did not know Joseph** = (“Exodus” 1- -8) = erased any evidence of his existence following the Exodus.

Anyhow: **Joseph's Water = Bahar Yusef Canal**.

Dr. Janice Kamrin, a well-known explorer of ancient Egypt, presents in her fascinating book, **“THE COSMOS OF KHNUMHOTEP II At Beni-Hassan (1999)”**, an interesting interpretation about a historical document, written in **ciphers = 22+15 = 37**, which appears as the opening of an ancient Egyptian message, above a drawing of a mysterious **“Caravan”** on the north wall of the tomb of **Count Khnumhotep II (3)**. Dr. Kamrin suggests that this mysterious caravan (pages 93 – 96) is an **“Asiatic Caravan”**. As another alternative she calls this **Caravan The Aamu of Shu**.



Similarly to the expert explorers of ancient Egypt, **Goedicke and Kessler** (page 94 - 95), **Dr. Kamrin** does not reach a clear conclusion as to the undoubtedly historical event depicted by this drawing.

However, when looking beyond the numbers per se, it becomes apparent that the ciphers considered here are also an encrypted message, written as part of the **Hebrew numerological system**, representing the Name of **“Jacob” = “Israel” = [22+15]**.

Dr. Kamrin proposes a particular view on the subject of the **ciphers [22 + 15] = 37**: these, she believes, must simply be only the number of people who were part of the caravan. Undoubtedly, as a logical conclusion, **Dr. Kamrin** could think nothing else, and I do not object to this thesis.

However, **let us examine the symbols appearing in the drawing as “The Israelite’s Caravan”**:

A. The Background: On the north wall of the tomb of **Count Khnumhotep II (3)** at Beni-Hassan Egypt, one can find six horizontal rows that symbolize a “Joyous Life Time” at the **“Black Continent”** = (“psalms” 105- -23), under the powerful monarch **Khnumhotep II**.

B. The Caravan: The face of a large-scale figure of the Great Black Count is welcoming the caravan which includes **pale-skinned people** dressed in **“Striped Skirts”** = (“Genesis” 45- -22) = appearing at row **(3)**. The artist designed these people as to express a “Semitic Line of Head, Shape of Beards and Body language” (Kamrin 1999, page 93).

Symbolically, this caravan includes: **8 men + 3 children + 4 women**, numbers which correspond to the **11 brothers of Joseph + 4 Mothers of Jacob’s family**.

C. The Offerings: Two pale-skinned persons (page 94), at the head of the caravan proposing to the Count a **“Young Ibex”** = a symbol of = (“Genesis” 46- -34) = the **“Shepherd’s family”** and a **“Young Hind”** = a symbol of = (“Song of Songs” 2- -7) = the **“Israelite’s vow”**. The men in the caravan carry original weapons and the last pale-skinned person is an archer, holding a bow (page 93). The person in front of him holds an ancient harp. These items, as well as the **she-asses**, symbolize the **“Honorable”** status of the family. A Biblical documentation = (“Genesis” 45- -17-23) = points to orders coming from **Pharaoh and Joseph**: **“To send Wagons, 10 donkeys, and 10 she-asses”** for **Jacob’s** voyage.

D. The Text: According to **Dr. Kamrin**, two black Egyptian officials lead the caravan, in front of the pale-skinned people. The first, **Neferhotep** “son of the Count”, extends a sheet of papyrus as a letter from **Pharaoh Khakheperre** to his father, **Count Khnumhotep II** [probably it is the order to give the **Land of Goshen as proprietary to Israel** = (“Genesis” 47- -11)]. The second, **Khaty**, is “the Overseer of the hunters” (page 93). Undoubtedly, the presence of these two Egyptian officials, and especially of the Count’s son, proves a positive interest from the part of **Pharaoh Khakheperre** in this caravan. **Dr. Kamrin** proposes her translation for the text of the

letter, which appears above the drawing of the caravan: “**37 Asiatics arriving from Shu, and bringing black eye-paint, in year 6 under the Majesty of Horus, Uniter of the Two Lands, King of Upper and Lower Egypt Khakheperre**” (page 93).

- E. **The Gift:** We should consider the interesting riddle: why the gift of “**black eye-paint**” to **Count Khnumhotep II**? **Dr. Kamrin** proposes **Goedicke’s** point of view: as “**black eye-paint**” originated from Egypt, it is unlikely that the people on the mysterious “Asiatic Caravan” were merchants of such a commodity. **Goedicke** strongly believes that they were “**New Emigrants**”, perhaps a group of workers on arrival into Egypt (page 94). As a reliable “Time Table” was missing for making the desired historical connection to “Israel’s caravan”, **Goedicke** was content with the notion of “**Emigration**”. Both interpretations refer to the hieroglyph of the eye.

However, one can find the uses of “**black eye-paint**” as an ancient Middle Eastern custom, which appeared in the ceremonies of “Fortune-Telling”, “Futurism” and “Prophecy” as used by = (“Kings 2” 9- -30) = “**Queen Jezebel**”. Therefore, as a symbolic act, the offering of “**black eye-paint**” indicates a fulfillment of a prophecy dictated by God regarding “Israel in Egypt” = (“Genesis” 15- -13). In this context, the unique hieroglyph can be interpreted as **Zaphenath-paneah** = (“Genesis” 41- -45) = the title **Amenemhet II** gave Joseph.

- F. **The Location:** In her translation **Dr. Kamrin** proposes: “**Arriving from Shu**” as a place. But as a “Biblical Reader”, we can find = (“Genesis” 16- -7) = “**The rode of Shur**” as the main road which crosses the “Sinai Desert” from East [Eilat - Sues] to West, to ancient Egypt. Also it is well known that the “**Desert of Shur**” is an arid desert = (“Exodus” 15- -22) = found on the Eastern side of “**Baal-zephon**” = (“Exodus” 14- -9) = [Sues city] and down south a few kilometers along the eastern shore of the western gulf of the Red Sea [Gulf of Sues].
- G. The Title and -- **The Name:** At the front-base of the drawing appears a Title: “The Ruler of the Desert” -- and a **Name**.

Dr. Kamrin proposes that this is a title describing the status of the first pale-skinned person in the caravan, and reads it as: “**Chieftain Ibesha**” (page 94). **Goedicke** suggests reading the name as “**Abi-Sha(i)**” (page 95).

The name “**Abishai**” is of biblical origin. If we take the view that **Joseph** oversaw the documentation in this compelling drawing, then the name “**Abishai**” cannot be a name from the well-known list of his family members. Also, no other name that can be associated with the pale-skinned travelers appears in the drawing. In light of this, such a name can be none other than that of the “Guardian” of the caravan - the Angel with whom **Jacob** wrestled at the bank of river “**Jabbok**” = (“Genesis” 32- -23-29). This wrestling ended not before the Angel (An Undocumented Name) blessed him and named him “**Israel**”. Hence, from that moment he became the “Eternal Guardian

Angel of Israel”. Adding this name corresponds to the Egyptian custom of adding the “Guardian Name” of “**Horus**” as protector to **Pharaoh Khakheperre** (page 93).

H. **The Ciphers:** On the left hand side of the drawn Egyptian text appear **ciphers** in the sum of **37**, intentionally written in two rows. The first row is **[2 + 10 + 10]** and underneath it is another row: **[5 + 10]**.

There is no doubt that this numerological array symbolizes not a regular number, which would appear simply as **[10 + 10 + 10 + 6 + 1] = 37 arrivals**, but also a prophecy of “A Range of Times”, with the **ciphers [22+15]=[2200+1500]** representing **[Israel]**. The multiple meanings that a cipher in such ancient systems holds can be seen for example in the **cipher [8]**, that symbolizes both the name of Israel’s guardian angel=**[Abishai]** as well as the “Guardian Name” of the “God of Israel”.

In this case, the message of the text reads: **[22+15]=[Israel]’s grateful and peaceful shepherds and hunters arriving through the rode of Shur and as fulfillment of a prophecy bringing black eye-paint, in year 6 under the Majesty of Horus, Uniter of the Two Lands, King of Upper and Lower Egypt Khakheperre.**

At the same time, this number **37** – like all other hieroglyphs – fulfills more than one function. A significant clue to understanding the meaning of this number is its correspondence with **Joseph’s** age as documented in = (“Genesis”). Taken together, we can pinpoint **the 37th year of Joseph’s life** as the beginning of the 7 years of hard starvation.

The confluence of symbols appearing here can be coherently interpreted if it was indeed **Joseph** who documented this message in a fashion of the Hebrew numerological system to encode a symbol of a prophecy in the name of his father **[22+15]=[Israel]**.

Joseph, as an accepted prophet and messenger of the “God of Israel”, in order to save the **Dynasty of Pharaoh** and his father “**Israel**”, came to be an exceptional and beloved ruler of ancient Egypt. It is understandable that holding such a status gave him documentation privileges for a historical event that he himself achieved, as fulfillment of a prophecy = (“Genesis” 15- -13) = to settle his father “**Israel**” in Egypt. Following the significant identification of this given “**Point in Time**” -- “**In the year 6 of Pharaoh Khakheperre**” = the beginning of the 7 years of hard starvation = when **Joseph is 37 years old**, one must adopt a reliable “Time Table” which can prove the real connection between **Jacob** “**Israel**” and the caravan.

Those who can read a Hebrew Bible will find that the “God of Israel” dictated the “Biblical Time Table”, and its continuity is perfect. To clearly understand the Hebrew text, one can carefully use the Hebrew numerological system. As a compelling example, consider the deep meaning of the first Hebrew word opening the “Book of Genesis”: **[Bereshit]=[4]=[Eternity]** -- its numerological **value** thus expanding to “An Eternal

Creation”. Similarly, in Biblical philosophy: = (“Isaiah” 63- -3) = “Blood” is the “Eternal Life”, which is dictated on a “Time Table” while the “Spirit of God hovered over our history from **Adam I** to eternity”.

Moses, who wrote the “Book of Genesis”, used that system of Hebrew numerology to expand his philosophy, as he used words in his Song = (“psalms” 90- -1-6) = which describe the “Eternal Time Table” of God’s existence. Following the profoundness of **Moses’** philosophy, one can understand how, by a symbol, it can measure “**An Eternal Day of God**”.

Symbolically, the Biblical Hebrew text uses “**7 Eternal days of God**” for the whole creation: **And God created the great sea-monsters...** (“Genesis” 1- -21) = like whales and dinosaurs. **And God created man in His own image in the image of God created He him male and female created He them...** (“Genesis” 1- -27) = a prehistoric creation.

The “Biblical Time Table” begins with the creation of **Adam I** = (“Chronicles 1” 1- -1) = (“Genesis” 2- -7)+(5- -2). In that “Point in Time”, God created by force of “A New Creation” a Human being that would be able to beget children for hundreds of years, while the prehistoric man = (“Genesis” 1- -27) = -- could live only a few dozen years.

Following is the Dictated Biblical Timetable, calculated according to data appearing throughout the Old Testament, with reference to both to Egyptian dynasties and historical events.

The Dictated “Biblical Time Table”:

4166- B.C. = **Month 1, spring** - The New Creation of **Adam I** = (“Genesis” 5- -2) = (“Chronicles 1” 1- -1).

The Dictated “Biblical Time Table” of Adam’s I Dynasty is divided into equal parts, each part constituting a period of 440 years.

Adam’s I Dynasty: = (“Numbers” 24- -17) = “Sons of Seth” = Balaam refers to Seth as the beginning of the dynasty in order to distinguish between the Creation of Adam and the consanguinity that followed.

130 + years **Adam I lived 930 years.**
4036- B.C. = **Adam I** at the age of 130 = (“Genesis” 5- -3) = begot **Seth**.

105 + years **Seth lived 912 years.**
3931- B.C. = **Seth** at the age of 105 = (“Genesis” 5- -6) = begot **Enosh**.
At that “Time” men began to invoke the God by “Name” = (“Genesis” 4- -26) = The Hebrew meaning of “Enosh” is “A Human Being”.

90 + years **Enosh lived 905 years.**
3841- B.C. = **Enosh** at the age of 90 = (“Genesis” 5- -9) = begot **Kenan**.

70 + years **Kenan lived 910 years.**
3771- B.C. = **Kenan** at the age of 70 = (“Genesis” 5- -12) = begot **Mahalalel**.

65 + years **Mahalalel lived 895 years.**
3706- B.C. = **Mahalalel** at the age of 65 = (“Genesis” 5- -15) = begot **Jered**.

162 + years **Jered lived 962 years.**
3544- B.C. = **Jered** at the age of 162 = (“Genesis” 5- -18) = begot **Enoch**.

65 + years **Enoch lived 365 years.**
3479- B.C. = **Enoch** at the age of 65 = (“Genesis” 5- -21) = begot **Methuselah**.

187 + years **Methuselah lived 969 years.**
3292- B.C. = **Methuselah** at the age of 187 = (“Genesis” 5- -25) = begot **Lamech**.

182 + years **Lamech lived 777 years.**
3110- B.C. = **Lamech** at the age of 182 = (“Genesis” 5- -28) = begot **Noah**. **Pharaoh Menes.**

503 + years = (Arithmetically based on Noah’s age although only 500 years are accounted for) **Noah lived 950 years.**
2607- B.C. = **Noah** at the age of 503 = (“Genesis” 5- -32) = begot **Shem** = The Hebrew meaning of “Shem” is “Name”.

The Deluge:

97 + years
2510- B.C. = **Noah** at the age of 600 = ("Genesis" 7- -11) = Greater Babylon sank under "**The Flood Waters**". (Methuselah drowned in the Flood Waters: precisely 969 years from the year of his birth)

Pharaoh Khufu.

1 + year A "Year of the Moon Time Table" = ("Genesis" 7- -11+24)+(8- -4-14) = Month 1, spring = **calendar of Noah:**
2509- B.C. = **Noah's Anniversary** at the age of 601 = ("Genesis" 8- -13) = Day 1 of Month 1:
End of Deluge.

Shem's Dynasty:

2 + years = ("Genesis" 11- -10) = 2 years. **Shem lived 600 years.**
2507- B.C. = **Shem** at the age of 100 = ("Genesis" 11- -10) = begot **Arpachshad.**

35 + years **Arpachshad lived 438 years.**
2472- B.C. = **Arpachshad** at the age of 35 = ("Genesis" 11- -12) = begot **Shelah.**

30 + years **Shelah lived 433 years.**
2442- B.C. = **Shelah** at the age of 30 = ("Genesis" 11- -14) = begot **Eber.**

34 + years **Eber lived 464 years.**
2408- B.C. = **Eber** at the age of 34 = ("Genesis" 11- -16) = begot **Peleg.**
The fall of the Tower of Babylon = ("Genesis" 10- -25)+(11- -1-9).
Eber - father of the Hebrew language.

30 + years **Peleg lived 239 years.**
2378- B.C. = **Peleg** at the age of 30 = ("Genesis" 11- -18) = begot **Reu.**

32 + years **Reu lived 239 years.**
2346- B.C. = **Reu** at the age of 32 = ("Genesis" 11- -20) = begot **Serug.**

30 + years **Serug lived 230 years.**
2316- B.C. = **Serug** at the age of 30 = ("Genesis" 11- -22) = begot **Nahor.**

29 + years **Nahor lived 148 years.**
2287- B.C. = **Nahor** at the age of 29 = ("Genesis" 11- -24) = begot **Terah.**

70 + years **Terah lived 205 years.**
2217- B.C. = **Terah** at the age of 70 = ("Genesis" 11- -26) = begot **Abram.**

99 + years (“Genesis” 12- -10) = Abram went down into Egypt: **Pharaoh Inyotef II.**
 2118- B.C. = **Abram** at the age of **99** = (“Genesis” 17- -24) = was circumcised and named **Abraham.**
 (“Genesis” 18- -1-33)+(19- -1-29) = Sodom and Gomorra.

1 + year (“Genesis” 25- -7) = **Abraham lived 175 years.**
 2117- B.C. = **Abraham** at the age of **100** = (“Genesis” 21- -5) = begot **Isaac** = (“Genesis” 17- -17) = **Sarah**
 was **90 years old** when she gave birth to **Isaac.**

60 + years (“Genesis” 35- -28) = **Isaac lived 180 years.**
 2057- B.C. = **Isaac** at the age of **60** = (“Genesis” 25- -26) = begot **Jacob.**

The “Israelite Generational Odyssey”:

91 + years = [Arithmetically based on Jacob’s age = (“Genesis” 47- -9)].
“Halley” **1966- B.C. = A Point in Time = $440 \times 5 = 2200$ = The course of Comet Halley = “The Star of Jacob” = (“Numbers” 24- -17) = crossed paths with the Dictated “Biblical Time Table” of Adam’s I Dynasty at the same time when a period of 440 years ends (and begins) on this chronology = **Jacob** at the age of 91 begot **Joseph** = (“Genesis” 30- -24). {**Joseph’s Anniversary** coincides with the salvation of the Jewish population in the Persian Empire from the evil lot designed for them by **Haman** = (“Esther” 9- -1)} = [Day 13 of month 12]. **Jacob** worked for **Laban** = (“Genesis” 31- -38) = **20 years** = A few days after **Jacob** begot **Joseph** he received an order from = (“Genesis” 31- -3-17) = God and His messenger: “Go back to Canaan”. Later in that spring = (“Genesis” 31- -35) = on his way to Canaan **Jacob** was named **“Israel”** = (“Genesis” 32- -29) = by an angel with whom he wrestled.

17 + years = (“Genesis” 41- -46) = 17 years.
 1949- B.C. = **Joseph** at the age of 17 was sold in Egypt = (“Genesis” 37- -36).

13 + years = (“Genesis” 41- -46) = 30 years.
 1936- B.C. = **Joseph** at the age of 30 = (“Genesis” 41- -46) = solved the dream of Pharaoh: **Amenemhet II.**

7 + years = (“Genesis” 41- -46) = 37 years.
 1929- B.C. = **A Point in Time = Joseph** at the age of **37** became the Ruler over all the land of Egypt = **Year 6 of Snusret II = The beginning of the 7 years of hard starvation. Joseph’s Water arrive into Fayoum.**

2 + years = (“Genesis” 45- -6) = [“2 year now the famine has been”] = 9 years = [5 more years for famine].
 1927- B.C. = **A Point in Time = Joseph** is 39 years old when **Jacob Israel** at the age of **130** = (“Genesis” 47- -9) = comes into Egypt. **As fulfillment of a prophecy** = (“Genesis” 15- -13) = to settle **Israel** in Egypt. It was **Senusret II = “Pharaoh Khakheperre” of Dynasty XII** who ordered to settle **Israel** in Goshen at “Fayoum”.

The descendants of **Levi**:

Gershon Kohath Merari Amram Miriam Aaron Moses were born in Egypt.

8 + years

1919- B.C. = a possibility for **Jacob** and **Joseph** to understand the prophesy of Abram = (“Genesis” 15- -13) = 400 years.

9 + years = (“Genesis” 47- -28) = 17 years.

1910- B.C. = **Jacob lived 147 years** = (“Genesis” 47- -28). Then mummified and buried: **Year 16 of Snusret III**. In order to perform the burial, **Joseph** and **Pharaoh Snusret III** marched the Egyptian Army = (“Genesis” 50- -9) = into Canaan. **On that voyage Snusret III took “Shechem”** (see www.touregypt.net/Kings.htm).

391 + years = (“Genesis” 47- -27) = [In Goshen at “Fayoum” - Increasing population to be Great = (many)].

1519- B.C. = **A Point in Time** = **“Exodus”** by **Moses** = (“Exodus” 12- -40) = **ended the 430 years in Egypt: Amenhotep I** = 430 years = “Range of Times” from = **Joseph** was sold in Egypt as fulfillment of a prophecy = (“Genesis” 15- -13). (Documented 400 years).

Moses = (“Exodus” 7- -7) = **at the age of 80**.

Some Major events on the “Odyssey of the Exodus” - by Days:

- A. **Matzoth** at the Evening of = (“Exodus” 12- -18) = “Day 14 of month 1” = **“Wednesday”**:
- B. 1. **At that Night** = **“Thursday”**: **Moses** took **Joseph’s bones** = (“Exodus” 13- -19).
 2. **“Thursday at midnight”**: The LORD smote all the firstborn in the land of Egypt. And on **“Thursday morning”** the Israelites were setting out on their voyage from [A center at “Fayoum”] = **“Succoth”** = (“Exodus” 13- -20), and always camped by desert fountains.
 3. **On Night 2**: The convoy camped = (“Exodus” 13- -20) = at **“Etham”** = **“Friday”**.
 4. **On “Friday morning”**: The convoy marched to **“Baal-zephon”** = (“Exodus” 14- -9) = and at that evening - changed direction to **“Pi-Hahiroth”** = [G. Ataka].
- A Point in Time**
- C. On Night 3 = **“The Seventh Day”**: “The God of Israel” divided the water of the western gulf of the **“Red Sea”** = (“Exodus” 14- -21).
 1. The Israelites marched from **“Pi-Hahiroth”** through the ruptured sea = (“Exodus” 15- -22) = to the **“desert of Shur”** at Sinai, traveling there for **3 days** without finding water = (“Exodus” 15- -22).
 2. **On Day 6**: The convoy marched south along the east shore of the **“Gulf of the Red Sea”** = (“Numbers” 33- -10).
 3. **On Day 28**: The convoy marched northeast on the way to **“Rephidim”** = [in the center of Sinai].
- D. Day 31: **“The Seventh Day”** = (“Exodus” 16- -1) = **“Day 15 of month 2”**: The Israelite community **“Grumbled”**. **At that night**: The convoy camped = (“Numbers” 33- -12) = at **“Dophkah”**.
- E. Day 32: **“Sunday”** = (“Exodus” 16- -13-15) = the 1st **“Manna”** = one omer for each:
 1. **At that night**: The convoy camped = (“Numbers” 33- -13) = at **“Alush”**.
 2. **In the morning of Day 33**: the convoy marched to **“Rephidim”** = (“Numbers” 33- -14).
- F. Day 33: 1st camp at **“Kadesh”** **Moses** smote the rock = (“Exodus” 17- -6-7) = **“Massah and Meribah”**:
 1. **“Rephidim”** = (“Numbers” 33- -14) = **“Kadesh”** = (“Numbers” 13- -26) = [Calls An NakhI on wadi El-Arish].
 2. **“Kadesh”** = (“Numbers” 13- -26) = (“Deuteronomy” 1- -19) = **“Kadesh-barneah”**.
 3. **On Day 34**: The war with Amalek = (“Exodus” 17- -8).
 4. **On Day 35**: The convoy marched south [through the valley of wadi El-Arish] for **11 days** = parallel to = (“Deuteronomy” 1- -2).

G. Day 37: **“Two omers of Manna”** for each = (“Exodus” 16- -26) = as on **“Friday”**.

A Point in Time

H. Day 38: **A documentation** = (“Exodus” 16- -29-30) = of the **1st “Holy Sabbath”**, as a **“Blessed Point in Time”** = (“Deuteronomy” 5- -14) = for the continuum of **“Sabbath” as part of the Eternal Time Table**.

I. Day 46: = (“Exodus” 19- -1) = **“Day 1 of Month 3”** = **“Sunday”** = the convoy reached **“Mount Horeb”**.

J. Day 51: = **“Friday”** = (“Exodus” 19- -16/20- -1-2) = “When it was morning, that there were thunders and lightnings and a thick cloud upon the mount, and the voice of a horn exceeding loud”... “And God spoke all these words, saying: I am the LORD thy God, who brought thee out of the land of Egypt”...

K. Day 187 of the year **“Kippur”**: **Moses** received the **“Covenant Tablets” II** = (“Exodus” 34- -28-29). On the top of **Horeb**, the **“Mountain of God”** = [“G. Serbal” at the south of the “Feiran Oasis”].

It was God’s intention to establish an **“Eternal True Connection”** with the descendants of **“Israel” that He Loved**, using the **“Ark and the Covenant Tablets”** as **“A Place” for “His Voice to be Heard”** while He dictated His prophecies and answers about any kind of **“Life Questions”**.

The descendants of **Levi** were the chosen tribe to serve Him, obeying His rules to preserve such a **“True Connection”**. At the head of that tribe stood a **“High Cohen”** as a chief servant of the **“God of Israel”**, constantly watching Day and Night, the honorable ceremonies for the **“Ark and the Covenant Tablets” II** which was in the **“Holy of Holies”** of the **“Meeting Tent”** and later on, of **“Temple I”**. When a **“High Cohen”** passed away, his first-born child (who is the only one that can inherit the post of **“High Cohen”**) immediately put his father’s garments on himself.

1st High Cohen **Aaron**: begot **Eleazar** = (“Chronicles 1” 5- -29).

The “Tabernacle of the Tent of Meeting”:

1 + year = [the Israelites camped at the foot of “G. Serbal” on the “Feiran Oasis”].
1518- B.C. = at Day 1 of Month 1 = (“Exodus” 40- -2) = **Moses** raised the **“Tabernacle of the Tent of Meeting”**. **Moses** and **Aaron** brought the **“Ark and the Covenant Tablets” II** into the **“Holy of Holies”** = (“Exodus” 40- -20-21) = and then the Cloud of God covered the **“Meeting Tent”**. A most primary duty of the **“High Cohen”** was a daily documentation in the diary of the **“Ark and the Covenant Tablets”** -- called the **“Book of Jashar”** = (“Joshua” 10- -13). In Hebrew, the meaning of **“Jashar”** is: **“Correct”**. However, the word **“Jashar”** = the 1st three letters of the word **“Isra-el”** in Hebrew = appears as an adjective in order to identify **“God”** Himself as giving **Jacob** the name **“Israel”**. In light of this: the **“Book of Jashar”** is the **“Book of the God of Israel”**. Above all, no stranger was allowed to visit the inside of the

“Meeting Tent”, especially no stranger was allowed to touch the “Ark and the Covenant Tablets”

+ **50 days** = (“Numbers” 10- -11-12) = [At Day 20 of Month 2] = The Israelites marched **11 days** = (“Deuteronomy” 1- -2) = to: 1518- B.C. = 2nd camp at **“Kadesh”** = (“Numbers” 13- -26) = (“Deuteronomy” 1- -19) = **“Kadesh-barneah”**:

+ **40 days** = **The Mutiny and Its Punishment** = (“Numbers” 14- -1-25). **“Kadesh”**, the fountain was = [An Nakhl on wadi El-Arish] = still active since **Moses** first smote the rock. The Israelites camped there for many days = (“Deuteronomy” 1- -46) = then they **“Turned to the Red Sea and compassed mount Seir”** = (“Deuteronomy” 2- -1) = for **1 Generation** as **38 years** = (“Deuteronomy” 2- -14).

38 + years = (“Deuteronomy” 2- -14) = [**1 Generation** that was not allowed to enter Canaan].

1480- B.C. = 3rd camp at **“Kadesh”** = (“Numbers” 20- -1) = Month 1 of the last year in Sinai: **Miriam** passed away. **“Waters of Meribah”** = **Moses** smote the rock with his rod **“Twice”** = (“Numbers” 20- -11-13). Then the Israelites took the = **“way of Arabah”** = [from Kadesh An Nakhl they turned to the south through wadi El-Arish. Then they turned to the = (“Numbers” 21- -4) = eastern gulf of the Red Sea] = (“Deuteronomy” 2- -8) = **“from Elath and from Ezion-geber”**, instead of passing through = (“Numbers” 20- -17) = the **“King’s way”**, known as the **“Rode of Shur”** = (“Genesis” 16- -7) = [Suez - An Nakhl - Elath].

+ **5 months** = **Aaron** at the age of 123 passed away = (“Numbers” 33- -38-39) = [Day 1 of Month 5] on the top of Mount **“Hor Hahar”** [by the eastern gulf of the Red Sea].

2nd High Cohen **Eleazar**: begot **Phinehas I** = (“Chronicles 1” 5- -30).

+ **7 months** = **Moses** at the age of 120 passed away = (“Deuteronomy” 34- -1-7) = [according to Day 10 of Month 1 = (“Joshua” 4- -19)] = [Day 7 of Month 12] = on the top of **“Pisgah”** at Mount **“Nebo”**.

= **12 months**

1479- B.C. = (“Joshua” 4- -19) = [Day 10 of Month 1] = The Israelites crossed the **Jordan River** to the west bank, entering into Canaan. **“Camp Passover”** = (“Joshua” 5- -10) = in **Gilgal... End of “Manna”** = (“Joshua” 5- -12).

45 + years = “Joshua’s Range of Times” = [Joshua conquered Canaan in 6 years = (“Joshua” 14- -10)].

“Halley” ** 1434- B.C. = (An undocumented date) = **Joshua buried Joseph’s bones at “Shechem”** = (“Joshua” 24- -32).

285 + years = “Judges’ Range of Times” = (“Judges” 1- -1) = after Joshua = coinciding with the “Book of Jashar”.

20 + years = 20 years as the 1st half = (“Samuel 1” 4- -18) = of **Eli** as a Judge for 40 years.

1129- B.C. = (“Judges” 13- -1) = The Israelites were **“In the hands of the Philistines”** for 40 years.

20 + years = 20 years as the 2nd half = (“Samuel 1” 4- -18) = of **Eli** as a Judge for 40 years = [(“Judges” 13- -1) = 1st half of Philistine dominion].

1109- B.C. = (“Samuel 1” 4- -11) = **“Gone is the Glory” with “Ebenezer’s fall”**: = (“Samuel 1” 4- -1).

10th High Cohen **Ahitub’s I**: his first-born child, who inherited the post of the “High Cohen”, was **Eli** = (“Samuel 1” 14- -3).

Ahitub I: begot **Zadok I** = (“Chronicles 1” 5- -34), his first-born child from his 2nd wife.

Eli: begot **Hophni** and **Phinehas II** = (“Samuel 1” 2- -34).

The Philistines defeated = (“Samuel 1” 4- -2) = Israel in the battlefield of “**Ebenezer**”. **Hophni** and **Phinehas II** took the “**Ark**” with the “**Covenant Tablets**” II into the battlefield = (“Samuel 1” 4- -5).

On that horrible day - “**The Glory was Gone**” - Philistines captured the “**Ark**” as well as the “**Covenant Tablets**” II = (“Samuel 1” 4- -11). On that day, **Hophni** and **Phinehas II**, the sons of **Eli** = (“Samuel 1” 4- -11) = were among the dead as fulfillment of a prophecy = (“Samuel 1” 2- -34). **Eli** himself also passed away on that historical day at the age of 98 = (“Samuel 1” 4- -15).

The “**Ark**” and the “**Covenant Tablets**” II were held = (“Samuel 1” 6- -1) = for 7 months in the country of the Philistines. The Philistines were punished severely by God, until they had no choice but to return the “**Ark**” and the “**Covenant Tablets**” II to the Israelites in Beth-Shemesh = (“Samuel 1” 6- -3-21).

20 + years = (“Samuel 1” 7- -2) = 20 years = [(“Judges” 13- -1) = 2nd half as the Israelites “In the hands of the Philistines”].
1089- B.C. = “**The Eben-ezer Stone**”: = (“Samuel 1” 7- -12).

430 years since the Exodus = a “Range of Time” is marked by an **Obelisk** erected by **Samuel** to indicate the historical victory on the Philistines.

The Kings “Time Table” coinciding with the = “**Book of Jashar**”: = (“Samuel 2” 1- -18).

[“**Biblical Time**” arithmetically based on David’s age] = (“Samuel 2” 5- -4-5).

2 + years (“Samuel 1” 8- -1) = **Samuel** grew old, so the Israelites demanded a **King** = (“Samuel 1” 8- -5).

(“Samuel 1” 17- -12) = “Saul stricken in years among men” = **Assumed... 58 years old based on** = (“Samuel 2” 2- -10).

1087- B.C. = **1st King**: = (“Samuel 1” 13- -1) = **Saul** = (age is missing, 58) = was King only for 2 years.

As God’s preference was to have a King who was a prophet so that His Spirit would be on him, He chose **Saul**. But **Saul** did not obey God’s order to attack Amalek and not to spare them = (“Samuel 1” 15- -3).

1 + year = (“Samuel 1” 14- -47) = **Saul** fought against all his enemies, and especially against the Philistines.
1086- B.C. = **A Point in Time** = the **7th** cycle of 440 years is completed as a full circle = progression of Time from the creation of Adam I: **David, son of Jess** = (“Samuel 1” 16- -5) = was **27** years old when **Samuel** rushed upon him the “**Spirit of God**” = (“Samuel 1” 16- -13). A few weeks later **David** killed **Goliath** = (“Samuel 1” 17- -49-50).

David a King in Hebron:

2 + years = ("Samuel 1" 13- -1) = Saul's reign lasted 2 years [and several months - based on David's age].
 1084- B.C. = David at the age of 29 + 6 months = ("Samuel 2" 5- -5) = a King in Hebron for 6 months.

1/2 + year = 6 months = ("Samuel 2" 5- -4-5).
 1083- B.C. = David at the age of 30 = ("Samuel 2" 5- -4-5) = ("Kings 1" 2- -11) = a King in Hebron for 7 years.

The Circle of David = 440 Years as a solution of Peace & Truth.

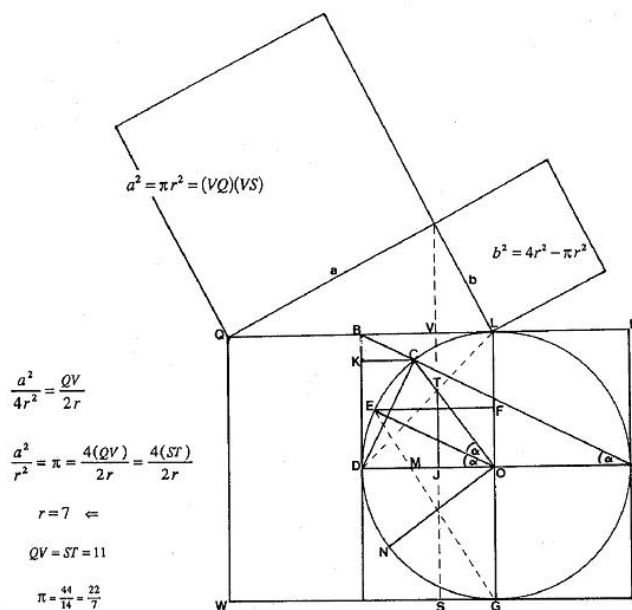

Such a circle was well known in Jerusalem and was used for devising the plan of the Temple. As shown here, its diameter divides into 7 equal parts and the circle itself divides into 22 equal parts, the same parts as those dividing the diameter. Each part contains 6 fingers = all that is needed for measuring the circle and its area.

David a King in Jerusalem:

7 + years

- 1076- B.C. = **A Point in Time David** at the age of **37** = (“Samuel 2” 5- -5) = (“Kings 1” 2- -11)
A King in Jerusalem for 33 years.

14 + years = [Assumed date according to: “I am but a little child” = (“Kings 1” 3- -7) = and David's age].
1062- B.C. = (An undocumented date) **David** at the age of 51 begot **Solomon** = (“Samuel 2” 5- -14).

The Mutiny of Absalom:

18 + year

- 1044- B.C. = **David: “After a period of 40 years”** = (“Samuel 2” 15- -7) = **as a King in Hebron and Jerusalem.**

At that “Time”: **Absalom**, son of **David**, as the successor of **David** conspired a mutiny under **Ahithophel’s “Best Advice”**. But the “God of Israel” had ordained to defeat **Ahithophel’s “Best Advice”** = (“Samuel 2” 17- -14).

“At the Top of the Mountain”:

+ 1 month = [Assumed date according to = (“Samuel 2” 15- -7)].

- 1044- B.C. = **Absalom’s mutiny** failed; a few days later, **David, at the** = (“Samuel 2” 15- -7) = **age of 70**, bought “The Threshing Floor” at the “**Top of the Mountain**” from **Araunah** the King of **Jebusite** = (“Samuel 2” 24- -24). In those days, for such a place to be a preferred area for threshing, it would have had to be a **flat surface**. One can conclude that the **huge, artificial rock** that stands “**At the Top of the Mountain**” in present days could not have existed then. Also, **King Solomon** could not have built a “Temple” for the “God of Israel” whose primary law is: = (“Zechariah” 4- -6) = “**But My Spirit**” with such a rock in the midst of its “Holy of Holies”. In particular, the area of the “Holy of Holies” in “**Temple I**” = **20x20 Cubits** = (“Kings 1” 6- -20) = would not have been able to cover the area of this artificial rock, as it is much wider. In light of this, the “**Capstone**”: = (“Zechariah” 4- -7) = “**At the Top of the Mountain**” is -- this **huge artificial rock** that was constructed under the orders of the “God of Israel” as = (“Isaiah” 28- -16) = “**A Touchstone**” in preparation for the “**Judgment Day**” = (“Malachi” 3- -17) = **as fulfillment of a prophecy.**

Ahitub I - lived for many years as he belonged to the “**Line of Kohath**”: he passed away at the age of 180

(An undocumented date).

+ Days = [Assumed date according to = (“Samuel 2” 15- -7)].

- 1043- B.C. = (“King 1” 1- -39) = **Solomon**, son of **David**, at the age of 19 a **King in Jerusalem for 40 years** = (“King 1” 11- -42).

Ahitub I: begot **Zadok I** = (“Chronicles 1” 5- -34).

It was on the day that **Ahitub I** passed away, that **King Solomon** ordered to bestow the post of “High Cohen” to **Zadok I** = (“Kings 1” 2- -27+35) = instead of **Abiathar** as fulfillment of a prophecy that came to **Samuel** about the house of **Eli** = (“Samuel 1” 3- -11-14).

11th High Cohen **Zadok I:** begot **Ahimaaz** = (“Chronicles 1” 5- -34).

(An undocumented date) = (“Kings 1” 3- -1) = **Solomon** married the daughter of **Pharaoh Psusennes I**.

“Temple I” in Jerusalem: “Ranges of Times” = written in the **“Book of Jashar”**
For **430 years** = (“Ezekiel” 4- -4-6).

4 + years = (“Kings 1” 6- -1) = [Year 4 = in the Month 2 of “Ziv”].
1039- B.C. = **A Point in Time** = (“Kings 1” 6- -1) = **480 years since the “Exodus” - King Solomon began constructing “Temple I”**. $400 + 480 = 880 = 440 \times 2$

8 + years = (“Kings 1” 6- -38) + (“Kings 1” 8- -2) = [7+1] = 8 years. = In the Month 7 of “Etanim”.
1031- B.C. = **15th High Cohen** **Azariah II** son of **Johanah** = (“Chronicles 1” 5- -35) = brought the **“Covenant Tablets” II** inside the **“Ark”** = (“Kings 1” 8- -6-9) = into the **“Holy of Holies”** and God’s cloud covered **“Temple I”** = (“Kings 1” 8- -10-11).
976- B.C. And it came to pass in the 5th year of king **Rehoboam**: “**Shishak** king of Egypt came up against Jerusalem” (“Kings 1” 14- -25) – It seems that **Shishak** is no other than “Akheperre Setepenre **Osochor**” the fifth king of the XXI dynasty of Egypt (984-978 B.C.) The second year to his reign was mentioned on a fragment of the Karnak Priestly Annals. He was the son of **Shoshenq A** by the Lady Mehtenweshkhet A. The Lady Mehtenweshet A was also the mother of Nimlot A, Great Chief of Ma and, thus, the Grandmother of **Shoshenq I** (1st king of XXII dynasty 945-924 B.C.) And it came to pass that “**Zerah the Ethiopian**” (“Chronicles 2” 14- -8) came up against king **Asa** in the 14th year of his reign... It seems that “**Zerah**” came with **Shoshenq I** to Canaan (947- B.C.) with an army of “Libyans and Nubians”... see (“Chronicles 2” 16- -8).

28 + years =

3. 1003- B.C. = **Rehoboam**, son of **Solomon**, at the age of 41 a **King in Jerusalem**.
For 17 years = (“King 1” 14- -21).

17 + years =

4. 986- B.C. = **Abijam**, son of **Rehoboam**, at the age of 31 (Assumed age) a **King in Jerusalem**. **For 3 years** = (“King 1” 15- -2).

3 + years (“King 1” 15- -2) = 3 years of **Abijam’s** reign.

5. 983- B.C. = **Asa**, son of **Abijam**, at the age of 16 (Assumed age) a **King in Jerusalem**. **For 41 years** = (“King 1” 15- -10).

41 + years = ("King 1" 15- -10).

6. 942- B.C. = **Jehoshaphat**, son of **Asa**, at the age of 35 a **King in Jerusalem. For 25 years** = ("King 1" 22- -42).

25 + years = [17+1+7] = 25 years of **Jehoshaphat's** reign = ("King 1" 22- -42).

7. 917- B.C. = **Jehoram**, son of **Jehoshaphat**, at the age of 32 a **King in Jerusalem. For 8 years** = ("King 2" 8- -17).

8 + years = ("King 2" 8- -17) = 8 years of **Jehoram's** reign.

8. 909- B.C. = **Ahaziah**, son of **Jehoram**, at the age of 22 a **King in Jerusalem. For 1 year** = ("King 2" 8- -26).

Athaliah as mother of **Ahaziah** a **Queen in Jerusalem...**

For 6 years = ("King 2" 11- -3).

7 + years

9. 902- B.C. = **Joash**, son of **Ahaziah**, at the age of 7 a **King in Jerusalem. For 40 years** = ("King 2" 12- -2).

40 + years ("King 2" 12- -1-2) = [23+14+3] = 40 years of **Joash's** reign.

10. 862- B.C. = **Amaziah**, son of **Joash**, at the age of 25 a **King in Jerusalem. For 29 years** = ("King 2" 14- -2).

29 + years = "Kings' Ranges of Times" coinciding with the "Book of Jashar".

11. 833- B.C. = **Uzziah** (**Azariah**), son of **Amaziah**, at the age of 16 = ("King 2" 15- -2) = a **King in Jerusalem for 52 years.**

Amos = ("King 2" 15- -1) = "Year 27 of Jeroboam King of Israel" = "**The Plummet**" prophecy.

12 + years = [According to = ("King 2" 14- -17)] = [Year 12 of Uzziah] = [Year 27 of Jeroboam] = [Correction].
821- B.C. = ("Amos" 1- -1) = [2 years before the earthquake] = **698 years since the Exodus: The prophet Amos** received a prophecy = ("Amos" 7- -8) = called "**The Plumb**" prophecy. That **Plumb** as a **Radius** which is divided to 7 equal parts, indicates a "Range of Time".

2 + years = (A "Range of Time" documented later) **A Point in Time** in light the Circle of David.

819- B.C. = **700 years since the Exodus: The Earthquake destroyed Jerusalem and Samaria.** = [Year 14 of Uzziah] = [Year 29 of Jeroboam] = [Correction].

1039 - 819 = 220 = 440/2

782- B.C. = The last year of Uzziah = (“Isaiah” 6) = the prophet Isaiah at the Temple = an **End** for solutions of **Peace & Truth** = no one will see the Circle of David.
737 years since the Exodus.

38 + years =

12. 781- B.C. = **Jotham**, son of **Uzziah**, at the age of 25 a **King in Jerusalem**.
For 16 years = (“King 2” 15- -33).

16 + years = (“King 2” 15- -33) = 16 years of **Jotham’s** reign.

13. 765- B.C. = **Ahaz**, son of **Jotham**, at the age of 20 a **King in Jerusalem**.
For 16 years = (“King 2” 16- -2).

16 + years = (“King 2” 16- -2) = [12+4] = 16 years of **Ahaz’s** reign.

14. 749- B.C. = **Hezekiah**, son of **Ahaz**, at the age of 25 a **King in Jerusalem**.
For 29 years = (“King 2” 18- -2).
In the year 6 of **Hezekiah**] = (“King 2” 18- -10) = **Samaria** was taken by **Shalmaneser King of Assiriah** = (“King 2” 18- -9-11).
The 10 tribes of Israel went to exile **after 260 years of their Kingdom**.

14 + years = 735- B.C. = **A Point in Time** in the 14th year of Hezekiah the son of Ahaz
The sun turned back 10 degrees on the sundial of **Ahaz**, to prove **Isaiah’s** words to **Hezekiah** = [who was on his deathbed] = that the God of Israel Ordered for him 15 more years = (“Isaiah” 38- -5).

15 + years = (“Isaiah” 38- -5) = [15 more years as fulfillment of a prophecy] + [14 years] = [29 years of **Hezekiah’s** reign].

15. 720- B.C. = **Manasseh**, son of **Hezekiah**, at the age of 12 a **King in Jerusalem**.
For 55 years = (“King 2” 21- -1).

55 + years (“King 2” 21- -1) = 55 years of **Manasseh’s** reign.

16. 665- B.C. = **Amon**, son of **Manasseh**, at the age of 22 a **King in Jerusalem**.
For 2 years = (“King 2” 21- -19).

2 + years (“King 2” 21- -19) = 2 years of **Amon’s** reign.

17. 663- B.C. = **Josiah**, son of **Amon**, at the age of 8 a **King in Jerusalem**.
For 31 years = (“King 2” 22- -1).

18 + years

645- B.C. = At the year 18 of Josiah: **A Point in Time**

And Hilkiah the high priest said unto Shaphan the scribe
I have found the book of the Law in the house of the LORD
And Hilkiah delivered the book to Shaphan and he read it... (“King 2” 22- -8)

13 + years (“King 2” 22- -1) = [18+13] = 31 years of **Josiah**. Killed at **Megiddo** = (“King 2” 23- -29) = by: **Pharaoh Necho II**.

18. 632- B.C. = **Jehoahaz**, = (“Jeremiah” 22- -11) = **Shallum**, son of **Josiah**, at the age of 23. A King in Jerusalem for **1/4 year** = (“King 2” 23- -31).

1/4 + year = 3 months in the winter = “Time” is passing to the next year.

19. 632- B.C. = **Jehoiakim**, son of **Josiah**, at the age of 25 a King in Jerusalem. For 11 years = (“King 2” 23- -36).

11 + years = (“Kings 2” 24- -12) = “Kings’ Ranges of Times” coinciding with the “Book of Jashar”.

20. 621- B.C. = **Jehoiachin**, son of **Jehoiakim**, sent by **Nebuchadnezzar II** to exile in **Babylon** accompanied by a large group of **Judea’s Elites**, among them (a little child) = (“Esther” 2- -5-6) = **Mordecai**.

1/4 + year = 3 months in the summer = Nebuchadnezzar II sent Jehoiachin into exile in Babylon.

21. 620- B.C. = **Zedekiah**, son of **Josiah**, at the age of 21 a King in Jerusalem. For 11 years = (“King 2” 24- -18).

Zedekiah ran away from **Nebuchadnezzar II** but was captured, and his eyes were taken out in exile = (“King 2” 25- -6-7).

In the summer: “Temple I” was destroyed by Nebuchadnezzar II King of Babylon, at year 19 of his reign = (“Jeremiah” 52- -12). At that “Point in Time” he sent the majority of **Judea** and **Jerusalem** to exile in Babylon. With the intention to keep strangers away from the exposed “Place” of the “Spirit” -- **22nd High Cohen Seraiah** buried the “Ark and the Covenant Tablets” II inside a huge artificial rock -- “The Touchstone” that was ordered to stand = (“Isaiah” 28- -16) = at the top of the “Temple Mountain”.

23rd High Cohen Jehozadak: he went to exile in Babylon = (“Chronicles 1” 5- -41).

Nebuchadnezzar II = (“King 2” 25- -18-21) = executed **Seraiah**.

The Dynasty of “King David” in Jerusalem Lasted 475 years...

5+ years = (“Ezekiel” 1- -1-2) = 5 years of Jehoiachin’s captivity when the prophecy was given on = [Day 5 of Month 4].
615- B.C. = (“Ezekiel” 4- -4-6) = (390+40) = **430 years** = [**Ezekiel**: In 6 years the end of “Temple I”].

1 + years = (“Jeremiah” 29 - -7-10) = [The exile will last 70 yrs] [Daniel is the ruler of the Babylonian Empire] = (“Daniel” 2- -48).
 614- B.C. = (“Ezekiel” 8- -1) = **Year 6** = (“Ezekiel” 9- -2) = **“A Man Dressed in Linen”** = **“Abishai”** appeared again.

4 + years = “Kings’ Ranges of Times” coinciding with the “Book of Jashar” = (“Ezekiel” 4- -4-6).
 610- B.C. = **428 years** = (“Ezekiel” 4- -4-6) = (390+40) = **the “Lifetime of Temple I”** which appears as a “Range of Time” that proves the **fulfillment of all the prophecies** = (“Prophetic Books”) = parallel to the documentation of **David’s dynasty** = (“Kings Books 1+2”) = as they were both destroyed at the same “Time”: 1039 - 430 = 609

1 + years = “Kings’ Ranges of Times” coinciding with the “Book of Jashar” = (“Ezekiel” 4- -4-6).
 609- B.C. = **A Point in Time** = **430 years** = (“Ezekiel” 4- -4-6) = (390+40) = **the “Lifetime of Temple I”** which Appears as a “Range of Time” that proves the **fulfillment of all the prophecies** = (“Prophetic Books”) = parallel to the documentation of **David’s dynasty** = (“Kings Books 1+2”) = as they were both destroyed at the same “Time”.

22nd High Cohen Seraiah: begot **Jehozadak** = (“Chronicles 1” 5- -40).
Nebuchadnezzar II = (“King 2” 25- -18-21) = executed **Seraiah**.

(“Jeremiah” 25- -11-12) = **“A Destroyed Temple” for 70 years:**

26 + years = (“Psalms” 137) = “Praying and weeping by the rivers of Babylon”.
 583- B.C. = (“Kings 2” 25- -27) = **37 years** since **Jehoiachin** was sent to exile, when **Evilmerodach King of Babylon** raised him up from prison:
 620 - 37 = 583- B.C.

A prophecy of **Jeremiah** about **Jehoiachin** = (“Jeremiah” 22- -30) = **“No descendant of his shall achieve a seat on the throne of David”... David’s Dynasty ended.**

23rd High Cohen Jehozadak: begot **Joshua** in Babylon = (“Ezra” 5- -2).

25 + years = “A Spiritual Center based in Babylonian exile”
 557- B.C. = **Year 1 of Cyrus II** = (“Ezra” 1- -1-4) = **“The Declaration of Cyrus II”:**
“Temple II” is allowed “To be built” in Jerusalem. **“Zerubbabel** and **24th High Cohen Jeshua”** = (“Ezra” 2- -2) = came from Babylon to Jerusalem and they began the construction of “Temple II”. (“Ezra” 4- -5) = **Cyrus II** suspended the work on the House. Also, later, **Ahasuerush** = (“Ezra” 4- -6 + 7) = he is **Artaxerxes = Cambyses**, suspended all work until the **2nd year of Darius I** = (“Ezra” 4- -24).

2 + years = “Zerubbabel and **Jeshua** the 24th High Cohen still in Jerusalem”.
 555- B.C. = **Year 3 of Cyrus II** = (“Daniel” 10- -1-6) = **“A Man Dressed in Linen”** = **“Abishai’s”** 1st speech:

13 + years = “Zerubbabel and **Jeshua** the 24th High Cohen still in Jerusalem” = “Esther” = not a word about “Temple II”.

542- B.C. = **A Point in Time** = **Purim** = **Spring** = Day 13 of month 1 = (“Esther” 3- -7-12) = **Year 12 of Ahasuerush** = **Cambyses**. Cambyse’s reign started in **Susa** (Susiana) while his father **Cyrus II** ruled in **Babylon**.

+ 12 months = [Day 13 of month 12 = for 12 months the horrified Jews were praying = (“Esther” 4- -3)].

541- B.C. = Day 13 of month 12 = (“Esther” 9- -1) = **A Reversal at Joseph’s Anniversary**.

2 + years = [at the end of the 3rd year = (“Daniel” 6- -1)] = Daniel in the “Den of Lions” = (“Daniel” 6- -17).

539- B.C. = **Year 1 of Darius I** = (“Daniel” 11- -1)+(12- -6-7) = **“A Man Dressed in Linen”** = **“Abishai’s”** 2nd speech: Daniel heard Gabriel’s Visions = (“Daniel” 9- -26) = [“An anointed shall be cut down”] = [“No Spirit”].

1 + year = **“Temple II Range of Time” for 608 years:**

Haggai and Zechariah’s “But My Spirit” prophecies = [Yes, “Zerubbabel lift up the Capstone”].
538- B.C. = **Year 2 of Darius I** = (“Zechariah” 1- -1) = (“Ezra” 4- -1-24) = **continuation of “Temple II”**.
A Range of Time” of = **70 years** = (“Zechariah” 1- -12) = **as fulfillment of Jeremiah’s prophecy** = (“Jeremiah” 25- -11-12). **Jeshua, the 24th High Cohen: he and Zerubbabel** built “Temple II” = (“Ezra” 5- -2) = in Jerusalem, while [following = (“Jeremiah” 22- -30) = **Jeremiah’s prophecy** and **Gabriel’s speech** = (“Daniel” 9- -24-26)] -- **Zerubbabel** was not able to lift up the **“Capstone”** = (“Zechariah” 4- -7) = which remained at the top of the “Temple Mountain”. Thus, “Temple II” was constructed on the northern side of that **“Capstone”** [under a plan of **Cyrus II** = (“Ezra” 6- -3-4)]. “Temple II” was completed after 4 years = (“Ezra” 6- -15). Later, **King Herod** constructed a “New Temple” above that **“Capstone”**. (Herod’s origin was from **Esau Dynasty** and the temple he constructed was a “Roman House”). However, that **“Capstone”** is still **“A Touchstone”** (sacred to the **Islam**) and is still ready for the **“Judgment Day”**. In light of this, no one **“But His Spirit”** will lift up this huge rock, as the intention of the “God of Israel” will be to give back the **“Ark and Covenant Tablets” II** into the hands of the “High Cohen”.

38 + years = “An Honorable Spiritual Center in Babylon”.

500- B.C. = (“Ezra” 7- -7) = **at year 7 of Xerxes, Ezra:** at the age of 111 came to **Jerusalem**.

Seraiah: = (“Ezra” 7- -1) = he was a father of **Ezra**, from the **“line of Kohat”**.

186 + years = 1. “A Spiritual Center of **Ezra** and Nehemiah in Jerusalem”. 2. “A Spiritual Center in Babylon”.

314- B.C. = **The Empire of Alexander the Great was divided between 4 successors** = (“Daniel” 8- -22).

“The Period of Wrath” = (“Daniel” 8- -19) = **“For at the appointed Time”:**

152 + years = “The period of Greek influences” = Discovery of **π** .

162 + years = “The Maccabees Kingdom = House of **Hashmonaim**.
70 + years = “The Mission of Jesus and his Apostles influencing the Human Race”.
 $538 + 70 = 608$

70 A.C. = **“Temple II” Destroyed by “Titus Emperor of Rome”**.

552 + years = “A Dark Exile in Europe, Northern Africa and Asia”.

622 A.C. = **Muhammad**.

1326 + years = “The Islamic Mission of Muhammad influencing the Human Race”.

1948 A.C. = **Day 5 of Month 2, spring: “The State of Israel” Declaration of Independence:**
 A “Range of Time” of Love = **103 generations** since **Jacob** wrestled
 “Abishai” and was named “Israel”.

33 + years = (“Isaiah” 43- -5-6) = [“Jews from all over the world coming back to their Ancestral Land”].

1981 A.C. = **A Point in Time** = **3500 years since the “Exodus”** = a “Range of Time”:
 Standing at the dawn of “A New Creation” = (“Isaiah” 66- -22).

40 + year (“Daniel” 12- -1) = “It shall be a Time unsurpassed in distress since nations began”... = **The Terror.**
Spring... of Terror... as a preparation for “**The Last War**”... = (“Ezekiel” 38/39) = by
 “Gog, of the land of Magog”... “The chief prince (in Persia) of Meshech and Tubal”...

2021 A.C.

6187 years since the creation of Adam I.

Following all of the above, one can choose to use such a reliable, dictated “Biblical Time Table”, which indicates God’s interest to preserve a “**True, broad and correct documentation of Israel’s Historical Destiny**”, and proves His dictated “Ranges of Times” on which the fulfillment of prophecies depends.

“The Star of Jacob”: = (“Numbers” 24- -17).

As the “God of Israel” forced a **Blessing** into the **speeches of the Magician Balaam**, there is no doubt that **Balaam** knew that the symbol for that “Generational Odyssey” appears together with the “**Star of Jacob**” = (“Numbers” 24- -17).

Halley is a **comet** that appears every **76 years**. Since **Moses** measured = (“Deuteronomy” 2- -14) = **1 Generation** as **38 years**, one can find a symbol of a “Double Step in a Range of Time of 76 years” on the “Generational Odyssey” as **[38 x 2] = 76 years**. Using this connection, one can call **Halley** = “**The Star of Jacob**” = (“Numbers” 24- -17).

One cannot forget:

The Pharaohs of Dynasty XVIII through the coming **80 years:**

Tao II

Kemose

Amenhotep I

1519- B.C. = **A Point in Time** “The God of Israel” divided the water of the western gulf of the “Red Sea” = (“Exodus” 14- -21). **The “Exodus”:**

Moses = (“Exodus” 7- - 7) = **at the age of 80.**

In those days (one cannot forget) the Exodus was setting out from “**Succoth**” = (“Exodus” 13- -20) = at “Fayoum”, marching due northeast, in the direction of the “Sinai desert”. In front of a fortress called “**Baal-zephon**” = (“Exodus” 14- -9) = [Sues city] the 600 first-class chariots and other warriors of **Amenhotep I** waited and stopped the convoy, that changed direction to the western shore of the western gulf of the “Red Sea” [Sues Gulf]. Down at the southern foot of a mountain [G. Ataka], at a place named “**Pi-Hahiroth**” = (“Exodus” 14- -9) = “**The House of Obelisks**”, the Israelites were trapped. It was at the middle of the night of “**Sabbath**” when “The God of Israel” = (“Exodus” 14- -21) = divided the water of the “Red Sea”. One can believe it or not, but: the existence of the “**State of Israel**” is a strong evidence for such a true historical event that began with = (“Genesis” 45- -7) = **Joseph’s** mission who documented his father’s caravan coming into Egypt with the encoded **ciphers** = **[22+15]** representing the Name of “**Jacob**” = **[“Israel”]** that fits that point in time when he was the ruler over all the land of Egypt at the age of **37** years. It was clear to **Joseph** that deciphering this code depends on the understanding of the Hebrew language and the numerological system that represents it, and when he prophesized the Exodus = (“Genesis” 50- -27) = he had no doubt that this would be a historical reality. [Even though he did not know God would divide the “Red Sea”, as the “**Sabbath**”, at his days, did not take a part of **Noah calendar** and of the “Biblical Time Table” dictated by God] **Joseph** was certain, however, of the eternal existence of the nation of the **Jews**.

1971 A.C. = I was able to see the solution of **Peace & Truth**.

[8]=3500 + years

1981 A.C. = Following all the wonders of the historical story above, we must consider once again our philosophy regarding the “Israelite Generational Odyssey” under the guard of “**Abishai**”, as was documented by **Joseph**.

40 + year (“Daniel” 12- -1) = “It shall be a Time unsurpassed in distress since nations began”... = **The Terror**.
2021 A.C. = **Spring... of Terror...** as a preparation for “**The Last War**”... = (“Ezekiel” 38/39) = by “**Gog, of the land of Magog**”... “The chief prince (in Persia) of Meshech and Tubal”...

6187 years = Love since the creation of Adam I.

And then = (“Daniel” 12- -7) = when our **Lord** shall make an end while breaking in to pieces the “**Capstone**”, the prophecy of “**Isaiah**” = (27- -6) = will take place to flourish and make fruitful our world, to put an end onto all those elegant or foolish lies that cause all the bloodshed and famine -- and as “**It will not be Late**” = (“Habakkuk” 2- -3) = one would have to realize that such a dictated

“Point in Time” of = (“Isaiah” 66- -22) = “**A New Creation**” will come. So we can wish that “**His Spirit**” shall break the “**Capstone**” into pieces and use it as “**A Touchstone**” on His “**Judgment Day**” with the intention to give back the “**Covenant Tablets**” II to us, for saving “**Our Eternity**” by “**Peace & Truth**” = (“Jeremiah” 33- -6). The “**Voyage of the Israelite Caravan**” as “**Jews and Others**” is continuing together with the streaming water of that ancient canal that was erected by **Joseph**. Although the ancient pharaohs tried to erase **Joseph’s** name from existence, still, we find it in Egypt at his **37th** year of his life, and still, no one can erase the name of “**Bahar Yusef**”.

Sycamore-trees Spring 1946

